

We Care Packages

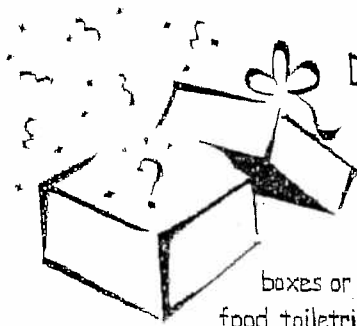

During the holidays and for every Birthday, Meals-On-Wheels and our community of generous volunteers provide our seniors with a special goodie bag to say, "We Care".

What are they? We Care Packages can be brightly covered shoe boxes or small gift or decorated paper shopping bags filled with useful and fun food, toiletries and small personal items. Boxes can be assembled with a male or female in mind and can include personal note of well wishes from students and volunteers.

What goes in a Care Package? Items we all can use; foods, snacks, personal care items, convenience goods & fun things! Travel sizes work best. Suggested items for Goodies, toiletries & personal care:

Socks	Past-it notes	Shampoo	Nail files & clippers
Dish towels	Stationary	Deodorant	Magnifying glasses
Potholders	Postage Stamps	Lotions	Pill Boxes
Jar openers	Toothbrushes	Band-Aids	Night lights
Pens	Toothpaste	Swabs	Playing cards
Sharpened pencils	Mouthwash	Cotton balls	Sewing kits
Notepads	Floss	Combs	Photo frames
Envelopes	Soap	Small brushes	Tissues (small)

Snacks & Foods

Sample sizes, single servings, and individually wrapped items are best suited for packages. Meals-On-Wheels also serves many clients who have special dietary needs. We encourage volunteers to put together boxes and bags geared towards low sodium, low fat, bland or sugar free (diabetic diets).

Fat Free Cocoa	Applesauce-regular & Unsweetened	Small Jellies & Jams	3oz- Boz Cans:
Sugar Free Cocoa	Granola bars	Peanut Butter (Small)	Tuna
Teas	Oatmeal	Nuts	Chicken
Coffee	Cereals	Cup'O Soup	Peas & Carrots
4oz-Boz cans of Juice	Crackers	Cup'O Noodles	Fruit in Light Syrup
Fruit Cups	Cookies	Ensure	Juices (V-8, Tomato)
Dried Fruit (sealed)		Boost	Vegetables

No

No's

Many items, while thoughtful, are not appropriate for some of our seniors. Please avoid:

- Razors
- Aspirin, Tylenol or Ibuprofen
- Over-the-counter Cold remedies
- Cough Drops
- Lipstick & Cosmetics
- Candles
- Matches & Lighters
- Flammable Liquids (i.e. Nail Polish, Rubbing Alcohol)
- Canned items larger than 10oz.
- Perishable foods
- Pasta & Rice mixes that serve 2 or more.
- Expired /dented cans
- Food in glass containers
- Hot/Spicy foods
- Exotic foods (Sardines, smoked salmon etc)
- Alcoholic beverages
- Juice "Bags"



NO. COUNTY MEALS-ON-WHEELS
930 BOARDWALK STE. C
SAN MARCOS, CA 92069
760-736-9900

Lona Vance

Meals-On-Wheels Creative Care Packages!

Kids get creative! Little Shopping bags get colorful!

*Thank you
for your
interest*

*Loma
Vance*

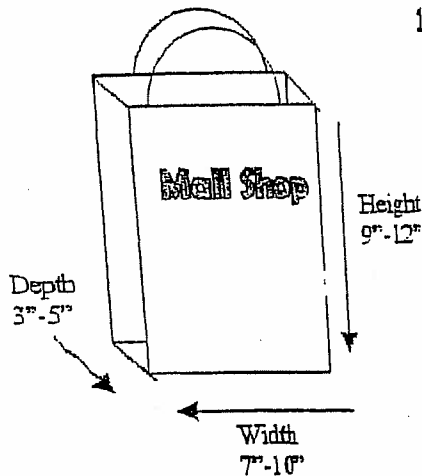

1. Save your small shopping bags from the Mall! Pick Colorful ones with handles! Not too Small, Not too Big!

2. Got Kids? Give them a piece of construction paper cut to the size of the front of the bag. It might even be 8" x 10"- How Easy! Give them crayons, may be some glue and construction paper and let them create!

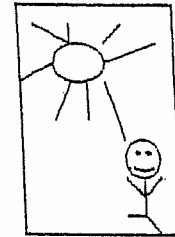

3. Glue the Art work over the label (Yes, the Nordstrom labels too!) And you have a great "We Care" package Bag ready to go!

Not a Kid? No problem! The face of an old greeting card, a scrap of wrapping paper, even a pretty photo from you favorite magazine will work well too!

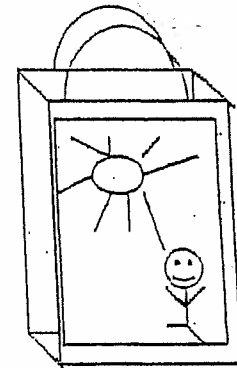

Old Shoe Boxes get a new life! Cover them, Color them!

Please wrap your tops and bottoms separate!
(We need to be able to peek in each box to ensure the contents haven't spilled or spoiled in transit.) Please keep in mind boot boxes are often too big!

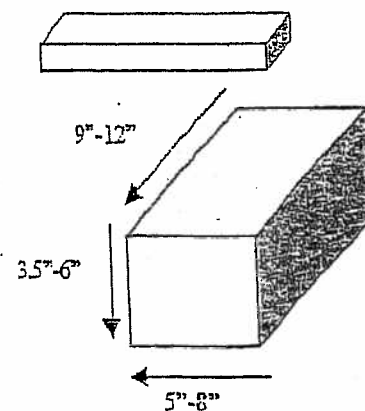

NO. COUNTY MEALS-ON-WHEELS
930 BOARDWALK STE. C
SAN MARCOS, CA 92069
760.724.0000